



Devil Technologies

DTR-101

Advanced Control Surface for
Digital Audio Workstation



DTR-101

Advanced Control Surface for
Digital Audio Workstation



DTR-101 is a top class control surface for Digital Audio Workstation and it is a must for any professional recording studio.

The main features of DTR-101 are: the highest number of strip controls now available in a DAW control surface, an outstanding user visual feedback and a high level of control surface customization.

DTR-101 maximizes your results and it is really time saving: relax yourself mixing all your projects without watching the DAW monitor. Use DAW mouse and keyboard only for editing!

DTR-101 channel strip bays have one touchscreen each: on the touchscreen you can set up strip controls automation modes, show the plug-ins parameters of the channel strip you are working on, modify surround placement of the source and you can recall your pre-

ferred project layout (mapping between DAW virtual channels and console physical channel strips). You can also recall a “virtual transport control window” on the touchscreen.



Highlights

Fully configurable by the user: you can build and buy the perfect solution for you!

Modular surface: Are you growing up? DTR-101 grows with you by simple add-ons; you buy only what you need, you don't throw nothing away and you don't waste your money!

High flexibility: the smart control-node software architecture allows the easy implementation of new protocols for emerging DAW or Hardware Mix Engines.

Very high channel strip controls count.

One touchscreen for each "Channel Strip Bay" to manage plug-ins, automation and more.

Touch-sensitive rotary encoders and motorized faders.

Wide viewing angle displays.

Graphical parameter displays with international fonts.

High quality industrial-grade components.



How to build it

DTR-101 is made up of one or more "Channel Strip Bays" and one "Master Section Bay".

The entry-level "Channel Strip Bay" configuration is called "Base Configuration" and includes one "Faders Module", one "24-Rotary Module" and one "Touchscreen Module".

You can add one or two "Rotary Modules" and a "Meter Module" to reach the so-called "Full Configuration".

The "Master Section Bay" is composed of a "Master Module", a "24-Rotary Module", a "Touchscreen Module", a dummy plate and a "Meter Module".

This configuration gives you all the controls you can find in live, broadcast and post-production consoles.

Channel Strip bay

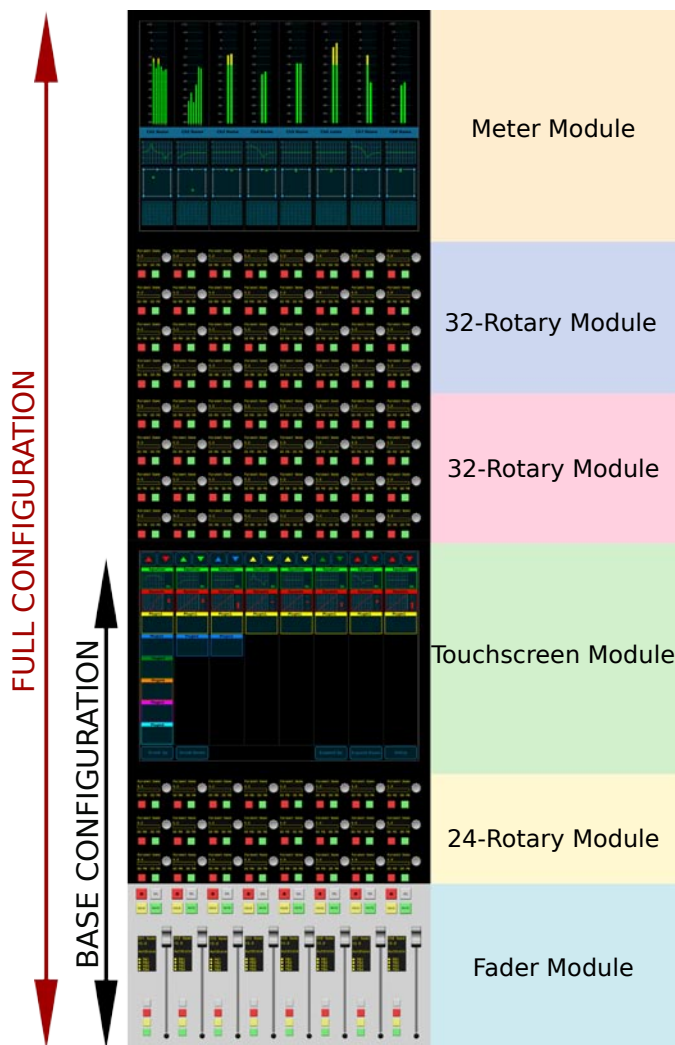

Master Section bay

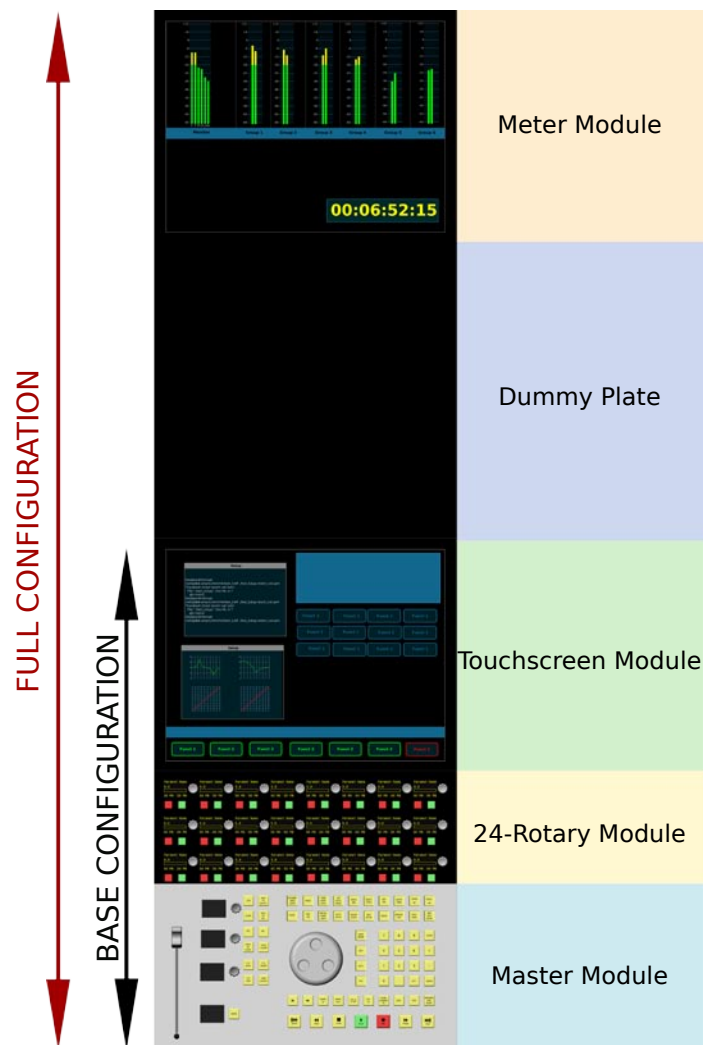

Both the “Channel Strip Bay” and the “Master Section Bay” are made of many stand-alone modules.

These building-blocks are electrically and mechanically autonomous.

All modules are connected to an internal network.

Thanks to the flat (not hierarchical) architecture of DTR-101, you can put modules where you like and buy a real custom-made console.

The internal network of DTR-101 is linked to the DAW by a “control node”.

The software nature of the protocol gateway inside the “control node” ensures the greatest flexibility you need to link one or more consoles to a network of DAWs.

For critical applications like broadcasting, the internal network can be redundant.

The mechanical frame of DTR-101 supports the “Channel Strip Bays” and the “Master Section Bay” modules and holds the electrical interconnections and the power supplies.

There are two frame versions:

- “Full Frame” version: it can host the highest modules number, so you can have up to 11 rotary encoders for each channel strip; you can have 12 bays without adding a central leg.

- “Compact Frame” version: table-mount frame; you get only the “Base Configuration”; with 16 channel strips you have an afford-

able entry-level system, but you can work in a very comfortable way too.

It is easy to switch from compact to full frame version: change only the frame and preserve your modules investment !

Do you have special needs? Devil Technologies will be glad to build custom frames or to put DTR-101 modules in user-made frames.

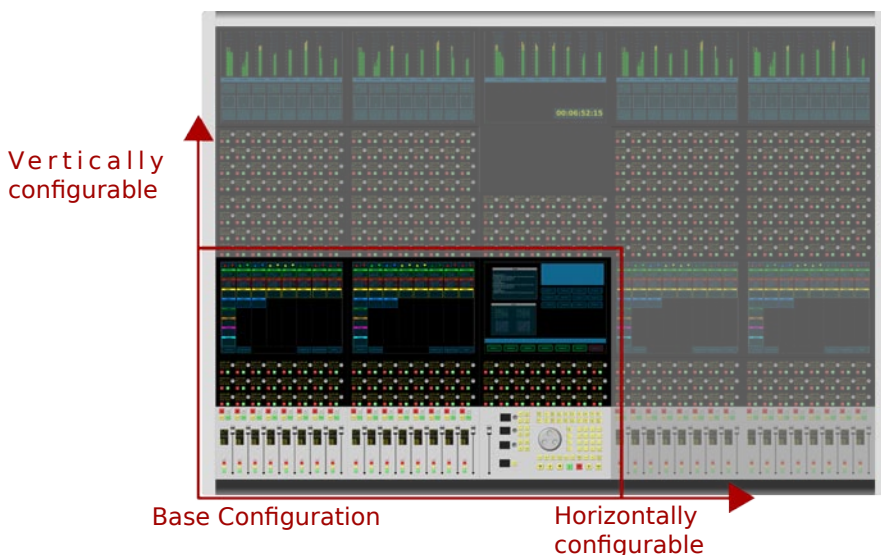
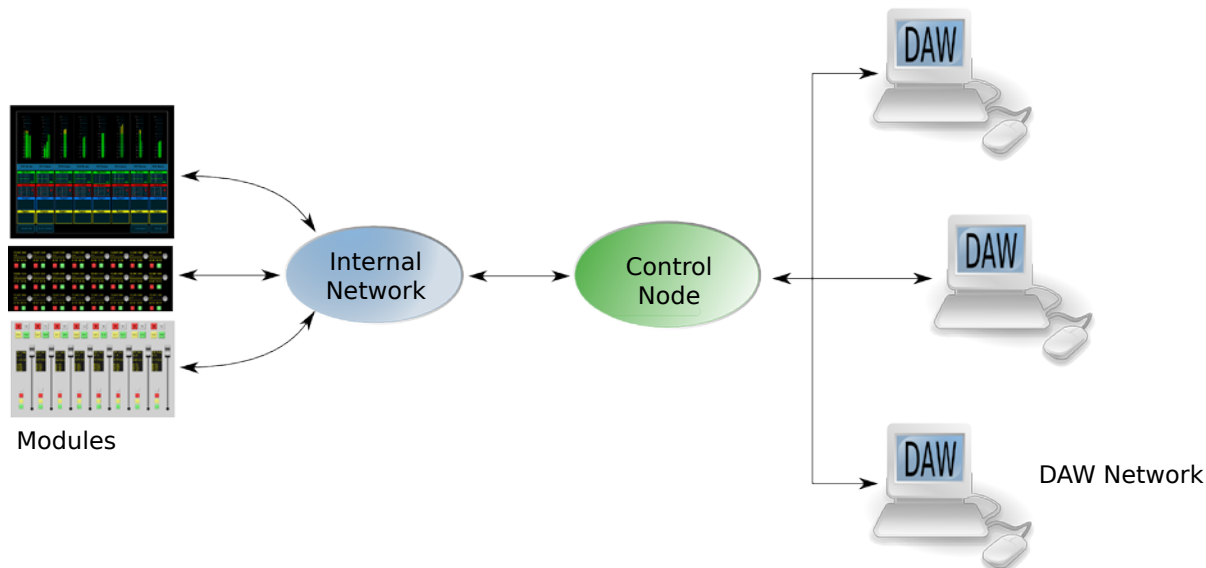

Example of vertical and horizontal scalability.

How to use it

With DTR-101 you get a full and intuitive control of your DAW, reaching a productivity never seen before.

DTR-101 lets you map all your DAW virtual mixer controls on the console: you can directly operate on all channel strip parameters such as gain, mute, stereo or surround pan, bus routing, monitor sends and many others.

Moreover, you have a direct control on all the channel strip plug-ins parameters.

With DTR-101 you can also modify the parameter automation status according to the DAW available automation modes.

The “Master Section Bay” offers to the recording engineer a wide range of controls: transport, solo mode and level, monitoring and talk-back.

Touchscreens are one of the most important features of DTR-101; with them you can immediately recall plug-ins parameters, automation functions and layouts.

The smart use of touchscreens and the high number of rotary encoders and switches really simplify your recording session. Reduce paging and difficult mnemonic procedures for parameters selection !

In order to improve mix automation, both motorized faders and rotary encoders are touch-sensitive and every switch has a dedicated “automation punch-in/out” push-button.

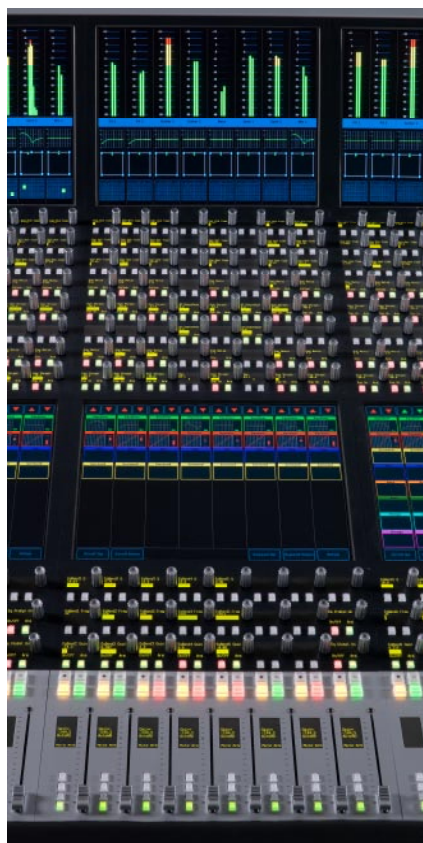
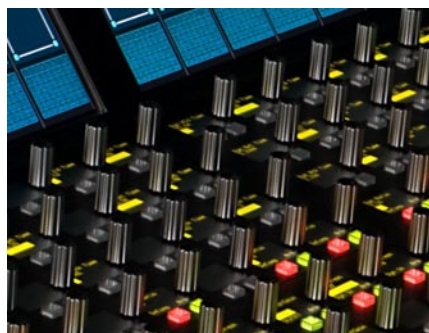

Channel Strip bay

DTR-101 channel strips are definitely the most complete solution never seen on a mixing console.

The “Fader Module” includes eight high quality touch-sensitive motorized faders. Every fader has software-enabled backstop PFL.



This module gives you eight illuminated pushbuttons for each channel strip: the bigger ones are for Mute, Solo, Channel-Select and Multi-Functions and the smaller ones are user-definable.

High resolution graphical displays are placed near each fader: they show channel name, gain value, fader automation status and smaller pushbuttons functions.

After the “Fader Module” you have one “24-Rotary Module”, one “Touchscreen Module”, one or two “32-Rotary Module” (or “24-Rotary Module”) and the “Meter Module”.

The basic unit of each “Rotary Module” is made of one high-resolution graphical display, one touch-sensitive rotary encoder and two push-buttons.

Every display shows the parameter name (up to 12 characters!), the parameter value (both in numerical and graphical form) which is dynamically updated by the DAW automation engine and the push-buttons functions.

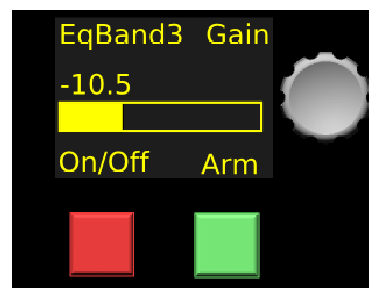

Thanks to the smart rotary encoder layout, knobs never hide displays. See them from any angle !

The "Touchscreen Module" includes a 15" wide viewing angle TFT display and an high quality touchscreen.

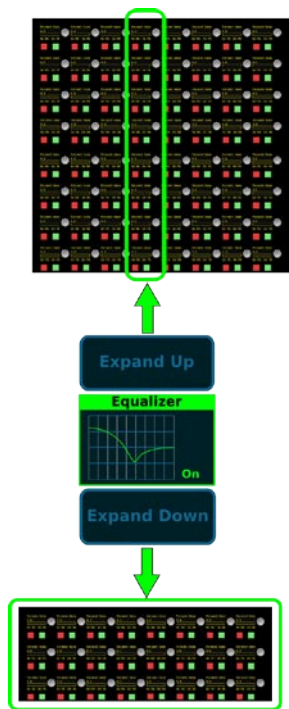

Here you are able to assign plug-ins to rotary encoders in a very simple way: touch the plug-in window on the touchscreen and press the "expand up/down" soft-buttons on the same touchscreen.

When a plug-in is "expanded-down" all its parameters are spreaded all over the "24-Rotary Module" controls; when it is "expanded up" you can control it using the related strip encoders in the upper optional 32-Rotary Modules.

In a "Compact Configuration" meters are shown in the upper part of the "Touchscreen Module": in this way you don't need a dedicated "Meter Module"; you save money and a lot of space!

The touchscreen lets you also set the channel strip controls automation mode, recall the channel layout and gives you access to a machine control window.

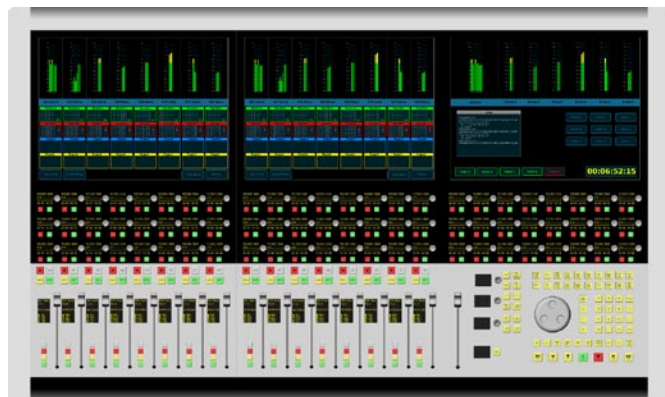

At the top of the frame you have the optional "Meter Module": it is a 15" wide viewing angle TFT display showing high resolution multiformat meters, EQ, pan, routing and channel name.

Both "Touchscreen Module" and "Meter module" can be software-upgraded.



Master Section bay

The "Master Section Bay" is made of the following modules: a "Master Module", a "24-Rotary Module", a "Touchscreen Module" and an optional "Meter Module".

In the "Master Module" you can find:

- Reassignable master fader.
- Control-Room level controls.
- Solo controls.
- Communications controls.
- Transport pushbuttons.
- Jog/Shuttle wheel and data-entry keypad.
- Automation management pushbuttons.

The "24-Rotary Module" in the master section bay is fully configurable and usually acts on monitor or stems levels.

The "Touchscreen Module" controls DAW-dependent global parameters.

In the master section bay "Meter Module" you can show master, stems or groups meters, Time-Code and routing informations.

Mechanical specifications (cm)

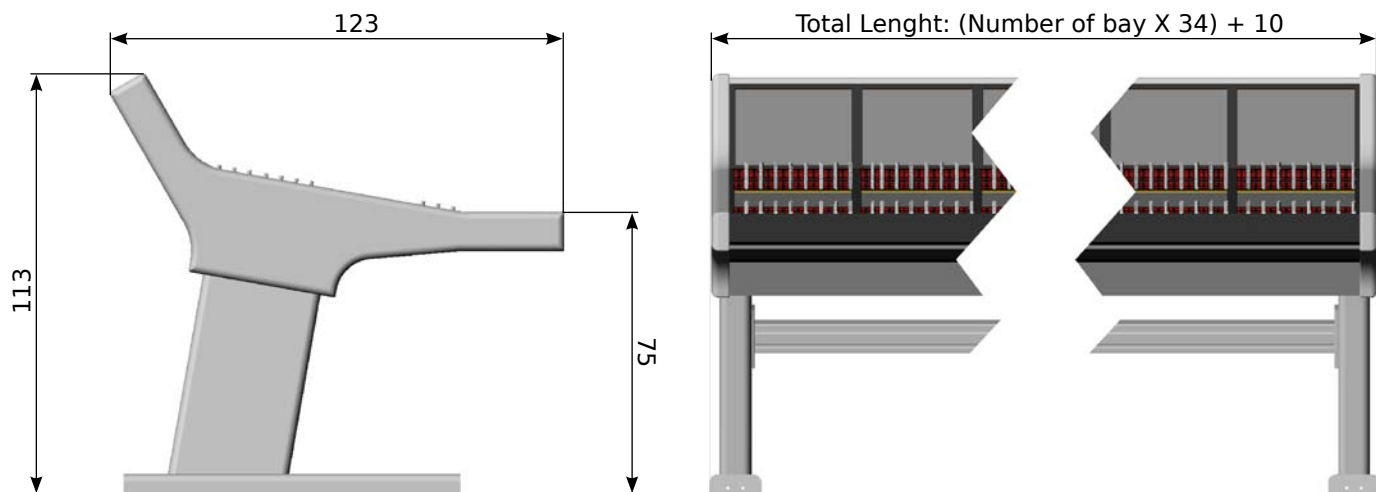

Examples of channel strip configurations (full frame)

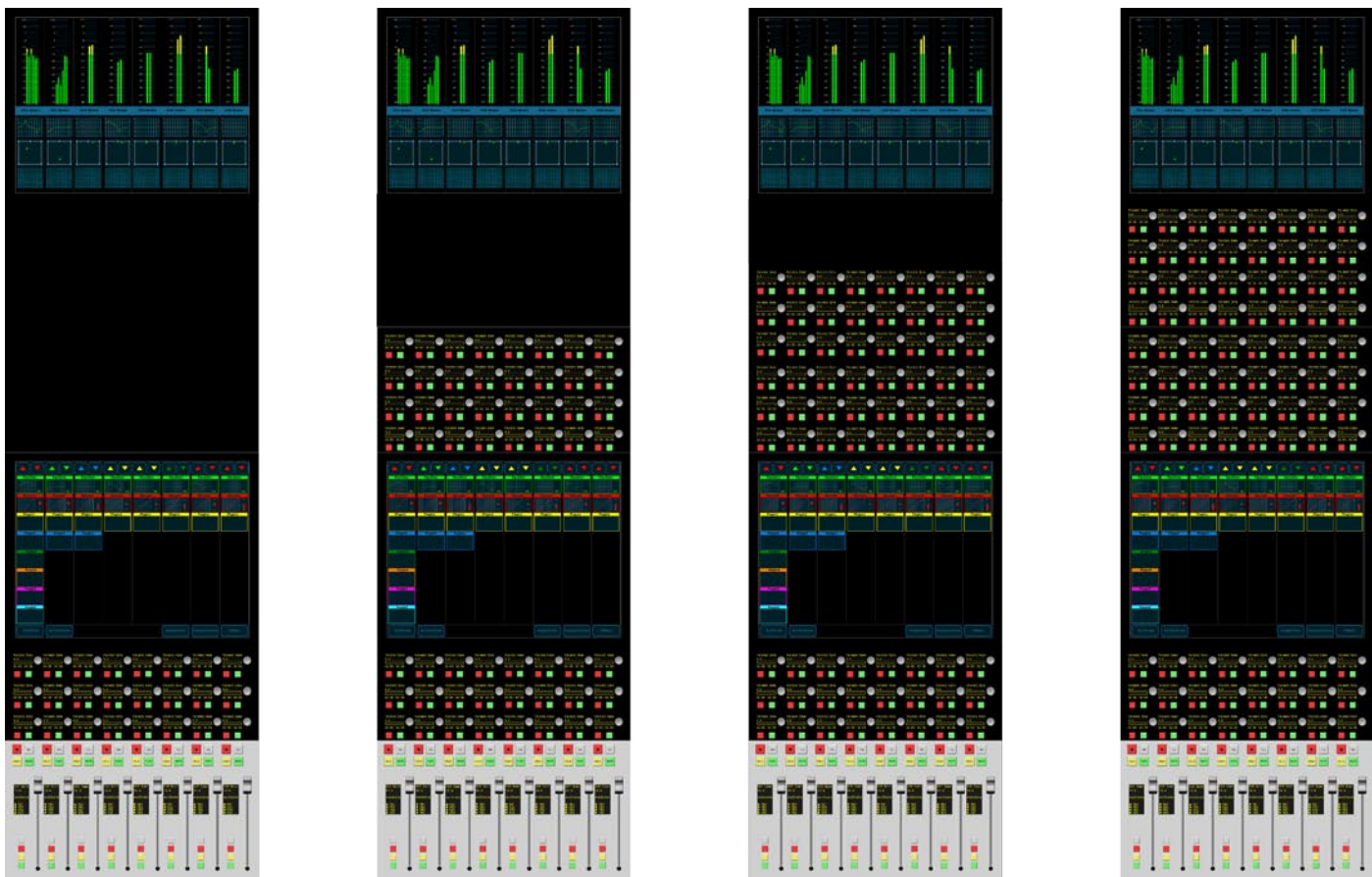

CONTACTS:

Devil Technologies
Via Rimembranze, 5
I-25038 Rovato (BS)
ITALY
Tel. +39 030 7722673
Fax. +39 030 7249329

Datasheet revision 1.0 28-12-2006